

# Chemiluminescence from Electron-Transfer Reactions

DAVID M. HERCULES

Department of Chemistry and Laboratory for Nuclear Science, Massachusetts Institute of Technology, Cambridge, Massachusetts 02139

Received October 21, 1968

Chemiluminescence arises from the production of excited electronic states by chemical reactions. It is merely one of several mechanisms whereby molecules dissipate chemical reaction energy. Originally, it was thought that oxygen or peroxide was necessary for a chemiluminescent reaction. However, recent discoveries have shown that chemiluminescence can be produced by simple electron-transfer reactions. In fact, light emission from these reactions is quenched by oxygen.

Figure 1 shows some representative chemiluminescence reactions, some involving oxygen and some not. There are diverse types of structures and reactions which are capable of showing light emission. Such diversity implies more than one mechanism of chemiluminescence should be possible, and this has been shown to be the case. The present Account deals with chemiluminescence from one type of reaction, namely those involving electron transfer. To appreciate the breadth of known chemiluminescent reactions, one can consult either of two recent reviews by Gundermann<sup>1</sup> or McCapra.<sup>2</sup>

## Criteria for Observing Chemiluminescence

It is necessary to meet a number of criteria for light production by a chemical reaction. These include sufficient excitation energy; the presence of a species capable of forming an excited electronic state; an emitter to give off the excitation energy; a rapid chemical reaction rate; and a reaction coordinate system favoring excited-state production over direct ground-state formation.

Before discussing these criteria in detail one should be concerned with chemiluminescence yield,  $\phi_{cl}$ . This may be defined as the ratio of the photons emitted by a reaction divided by the number of molecules reacted. For the reaction  $A + B \rightarrow C + h\nu$

$$\phi_{cl} = \frac{\text{einsteins of } h\nu}{\text{moles of A (or B) reacted}}$$

Chemiluminescence yield is a product of two separate efficiencies, one for production of an excited state,  $\phi_{es}$ , and one for emission from that state,  $\phi_f$  (the normal fluorescence quantum efficiency); *i.e.*,  $\phi_{cl} = \phi_{es}\phi_f$ . A low chemiluminescence yield can result either from low efficiency for excited-state production or low fluorescence efficiency. Therefore, in correlating structural effects on chemiluminescent reactions, one must

be certain to separate out the effect due to each factor. The efficiency of excited-state production is sensitive to all steps in a chemical sequence prior to formation of the excited state, and therefore structural effects on the kinetics of each step will be reflected in the value for  $\phi_{es}$ . Thus it is usually not meaningful to measure the overall chemiluminescence efficiency of a reaction, but one should measure the probability of excited-state production,  $\phi_{es}$ . Unfortunately few reliable estimates of this quantity are available.

**Energy Considerations.** If a chemical reaction is to emit light, sufficient reaction energy must be provided. If blue light,  $\lambda$  450 nm, is to be emitted, a minimum energy of 63.5 kcal/mol (2.75 eV) must be provided; for green light,  $\lambda$  500 nm, 57.1 kcal/mol (2.48 eV); for red light,  $\lambda$  600 nm, 47.6 kcal/mol (2.07 eV). The large energy requirement restricts the type of chemical reaction that can produce chemiluminescence; for example, hydrogen bonding reactions would not be very likely candidates.

Figure 2 further illustrates the need for sufficient excitation energy. The energy necessary to excite the fluorescent product, C, is indicated by the arrow linking curves C + D and C\* + D. For the case of a nonchemiluminescent reaction with a fluorescent product, producing C in an excited state is endothermic while ground-state production is exothermic. In such a situation, the reaction has no pathway other than direct ground-state formation. In the middle curve of Figure 2, the reactant curve A + B and both product curves cross in such a way that either excited-state or ground-state formation is exothermic. Here it is possible for the chemical reaction to be chemiluminescent depending upon the relative activation energies for production of the ground-state and an excited-state product.

The right-hand set of curves in Figure 2 shows the situation where excited-state production is just slightly endothermic. At room temperature the value of  $kT$  is 0.5961 kcal/mol (0.02585 eV), which means that small amounts of energy can be provided to a chemical reaction by thermal activation. Because chemiluminescence is observed as an absolute light intensity it is possible to detect reactions of low efficiency, and therefore light emission from endothermic reactions could be observed. If  $\Delta H^{\ddagger*}$  is on the same order of magnitude as  $\Delta H^{\ddagger}$ , as shown in Figure 2, the rates of the light-emitting *vs.* non-light-emitting reactions could be comparable.

**Excited States and Reaction Rates.** For a reaction to be chemiluminescent a species must be present to receive the excitation energy produced by the reaction.

(1) K. D. Gundermann, *Angew. Chem. Intern. Ed. Engl.*, **4**, 566 (1965).

(2) F. McCapra, *Quart. Rev. (London)*, **485** (1966).

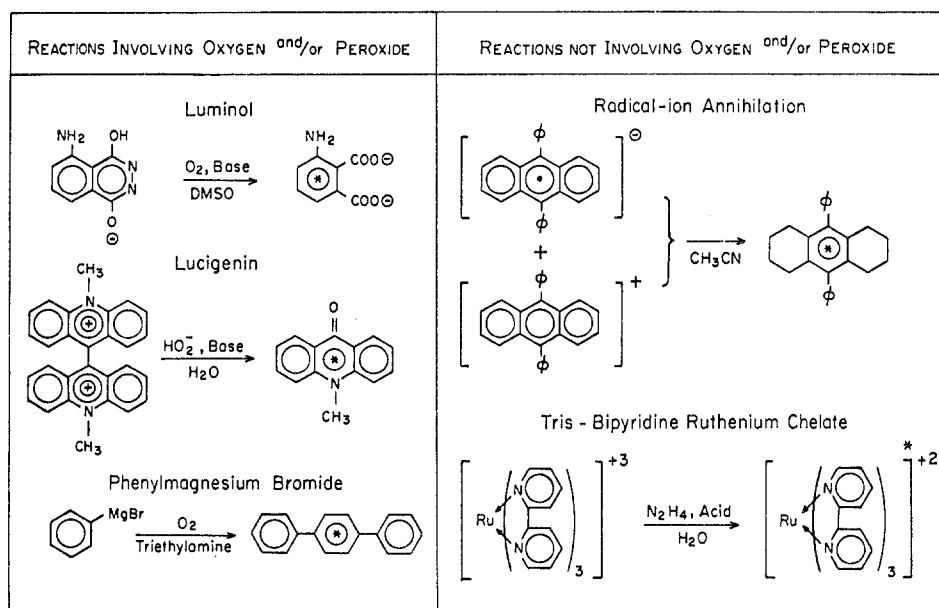

Figure 1. Examples of chemiluminescent reactions. The reactants and emitters are shown, along with reaction conditions.

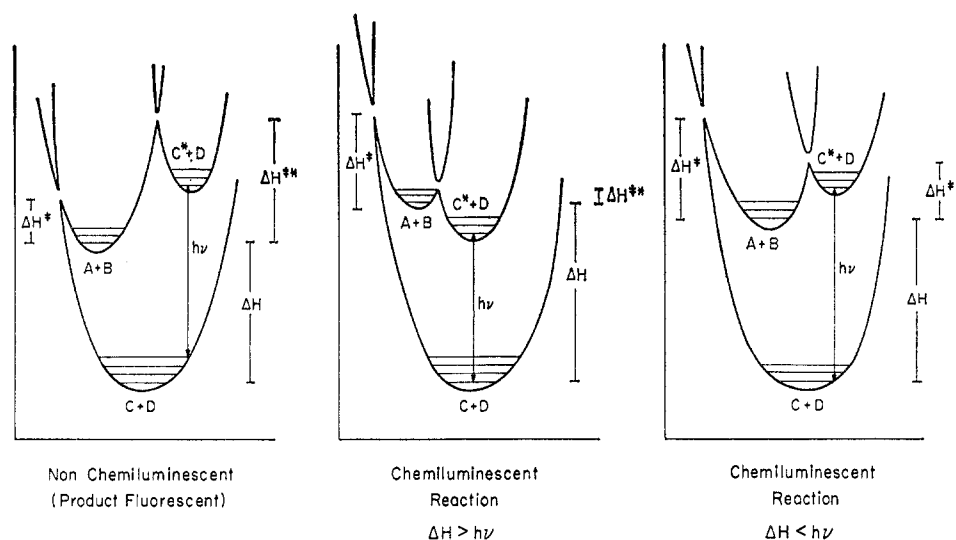

Figure 2. Reaction coordinate diagrams for chemical excitation processes:  $A + B =$  reactants;  $C + D =$  products formed in ground states;  $C^* + D =$  products formed with  $C$  in an excited state and  $D$  in the ground state;  $\Delta H =$  energy available from the reaction according to the usual thermodynamic criteria;  $\Delta H^\ddagger =$  activation energy for formation of products in the ground state;  $\Delta H^\ddagger^* =$  activation energy for formation of one product in an excited state;  $h\nu =$  energy necessary for the excitation  $C \rightarrow C^*$ .

The species to be excited initially must be involved in the chemical reaction since this is the only mechanism for transforming chemical energy to electronic excitation. The energy region of most chemiluminescent reactions corresponds to the electronic energies necessary for exciting large organic molecules, thus accounting for why chemiluminescence usually involves such systems.

In addition to having an excited state formed, an emitter must also be present. The emitter can be a fluorescent molecule produced by the chemiluminescent reaction or an energy acceptor, receiving excitation energy from an initially excited species. For example, the oxalyl chloride reaction produces chemiluminescence

characteristic of an added fluorescer, as do some peroxide decomposition reactions. These reactions are not chemiluminescent by themselves (or only weakly chemiluminescent), but addition of an energy acceptor produces bright light emission. The fact that luminol is strongly chemiluminescent while the unsubstituted phthalhydrazide is not indicates that compounds of similar structure can show dissimilar chemiluminescent behavior. The probable reason for this is that the product of luminol oxidation, 3-aminophthalic acid, is fluorescent in basic solution while phthalic acid, produced from the phthalhydrazide oxidation, is not.

The necessity for rapid kinetics in chemiluminescent reactions is a practical one. Detectors respond to

photon flux, and therefore a reaction must emit a reasonable number of photons in a given time interval in order to be detected. The kinetic requirement is unrelated to the efficiency of the reaction since a 100% chemiluminescent reaction emitting one photon per fortnight would go undetected.

**Reaction Coordinates.** Chemiluminescence from simple electron-transfer reactions has been treated by Marcus,<sup>3</sup> and the present discussion is based largely on his treatment. It is important to consider the relative probabilities of reactants giving the ground-state product directly *vs.* formation of an excited state. The probability is directly related to the free energy of the reaction and to the relative free energies of activation. In the center curve of Figure 2, the reactants can give either an excited-state product, C\* + D, or a ground-state product, C + D. Marcus<sup>3</sup> has shown that the free energy of activation is related to the free-energy difference between the product and reactant curves. If the free-energy difference is large, the energy for activation will also be large. Neglecting entropy effects, Figure 2 indicates that for most systems excited-state production will be more probable than direct return to the ground state because the free-energy change involved in excited-state formation is smaller. This is based on the assumption that the curves for A + C and C\* + D do not cross far above their minima, *i.e.*, there are small configurational changes between the ground state of the reactants and the excited state of the product. Otherwise the curves would be horizontally displaced from each other, and even though the free-energy difference was small, the large configurational change would cause the activation energy to become large and chemiluminescence would become less favored. One of the major considerations in looking for new chemiluminescent reactions, therefore, is that the configurational changes must be favorable. Unfortunately this is one of the most difficult parameters to evaluate *a priori*. However, simple electron-transfer reactions among polycyclic aromatic hydrocarbons or transition metal complexes are known to show small configurational changes between the ground and excited electronic states. Therefore, reactions involving these types of compounds represent potentially efficient chemiluminescent reactions.

### Chemiluminescent Systems

In this section selected examples of chemiluminescent electron-transfer reactions will be presented to illustrate some aspects of current thinking about the mechanisms of such reactions.

**Radical-Ion Reactions.** Cation radicals and anion radicals generated alternately at electrodes<sup>4,5</sup> can produce chemiluminescence as indicated by reactions 1, 2, and 3 of Table I. A large number of reactions

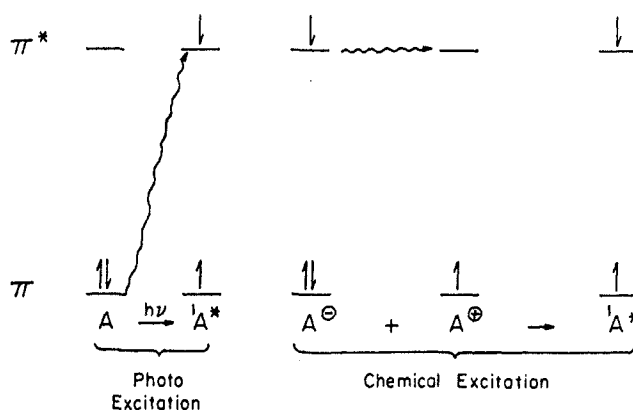

Figure 3. HMO diagrams for photoexcitation and chemical excitation in aromatic hydrocarbons:  $\pi$ , highest energy filled (bonding) HMO;  $\pi^*$ , lowest energy empty (antibonding) HMO; A, aromatic hydrocarbon;  ${}^1A^*$ , lowest excited singlet state of A;  $A^+$ , cation radical derived from A;  $A^-$ , anion radical derived from A.

Table I  
Generalized Mechanism for Electrochemically Generated Chemiluminescence

(1) $A + e^- \rightarrow A^-$	Reduction of A at electrode surface
(2) $A \rightarrow A^+ + e^-$	Oxidation of A at electrode surface
(3) $A^+ + A^- \xrightarrow{k_3} {}^1A^* + A$	Reaction of cation and anion to form excited singlet state
(4) ${}^1A^* \xrightarrow{k_4} A + h\nu_f$	Fluorescence of A
(5) $A^+ + A^- \xrightarrow{k_5} {}^3A^* + A$	Reaction of cation and anion to form a triplet state
(6) ${}^3A + {}^3A \xrightarrow{k_6} {}^1A^* + A$	Triplet-triplet annihilation
(7) ${}^3A + Q \xrightarrow{k_7} A + Q$	Triplet quenching.
(8) $A^+ + A^- \rightarrow {}^1A_2^*$	Reaction of cation and anion to form excimer
(9) ${}^1A_2^* \rightarrow 2A + h\nu_e$	Excimer fluorescence
(10) $A^- + P^+ \rightarrow {}^3A + P$	Anion reaction with electron acceptor to form a triplet state
(11) $A^+D^- \rightarrow {}^3A + D$	Cation reaction with electron donor to form a triplet state

involving cation and anion radicals produce light, and a detailed review of this subject will soon be available.<sup>6</sup>

Figure 3 indicates schematically light production by radical-ion reactions in terms of simple HMO diagrams. The highest filled and lowest empty molecular orbitals of the aromatic hydrocarbon, A, are designated  $\pi$  and  $\pi^*$ , respectively. Photoexcitation promotes one electron from a  $\pi$  to a  $\pi^*$  orbital to form the excited singlet state. The radical anion  $A^-$  is obtained by adding an electron to the  $\pi^*$  orbital while the radical cation is produced by abstracting an electron from the  $\pi$  orbital. Electron transfer between the anion and cation will be brought about by transfer of the electrons from the  $\pi^*$  orbital of the anion to the  $\pi^*$  orbital of the radical cation rather than to the  $\pi$  orbital.<sup>3,7</sup>

(6) D. M. Hercules in "Physical Methods of Organic Chemistry," Vol. I, 4th ed, B. Rossiter, Ed., John Wiley & Sons, Inc., New York, N. Y., in press.

(7) D. M. Hercules, R. C. Lansbury, and D. K. Roe, *J. Amer. Chem. Soc.*, **88**, 4578 (1966).

(3) R. A. Marcus, *J. Chem. Phys.*, **43**, 2654 (1965).

(4) D. M. Hercules, *Science*, **145**, 808 (1964).

(5) R. E. Visco and E. A. Chandross, *J. Amer. Chem. Soc.*, **86**, 5350 (1964).

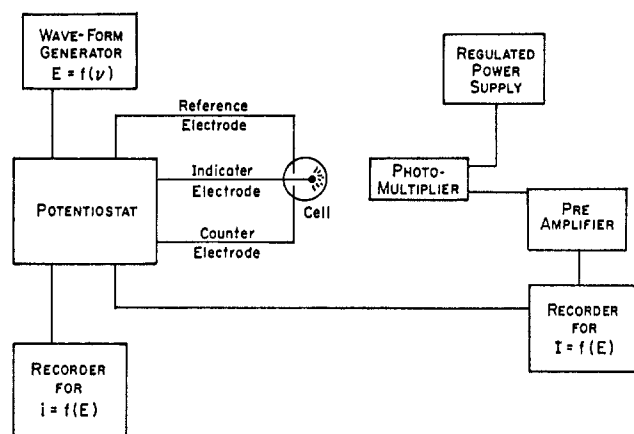

Figure 4. Schematic diagram of apparatus used to study electrochemically generated chemiluminescence.

Experimentally, chemiluminescence from radical-ion reactions has been studied with a combined photochemical and electrochemical apparatus shown in Figure 4. Current is passed at an electrode so that one species, say  $A^-$ , is generated and diffuses into the solution. Then the direction of current flow is switched so that the other species,  $A^+$ , is now generated at the electrode. Diffusional mixing of the two species in the vicinity of the electrode allows them to react providing the stability of both species is such that reaction between them can occur. The technique has the advantage that radical ions having very short lifetimes in solution (*ca.* 1 sec or less) can be used in chemiluminescent reactions.

Table I summarizes the general mechanism for radical-ion chemiluminescence. Feldberg<sup>8</sup> has computerized the solution of the boundary value problem for the double-potential-step method of electrochemical generation based on this mechanism. The double-potential-step method is an electrochemical technique whereby the electrochemical process described above is brought about by successively applied square waves. Under these conditions, the radical ions generated in the diffusion layer react and the light intensity is given by

$$\log \omega = -1.45(t_r/t_f)^{1/2} + 0.71 \quad (1)$$

where

$$\omega = \frac{fPF}{\pi^{1/2}\phi i_f} \quad (2)$$

$t_r$  is the duration of the second pulse and  $t_f$  the duration of the first pulse.  $F$  is the value of the Faraday,  $\phi$  the fluorescence efficiency of the emitter,  $i_f$  the current during the first pulse, and the product  $fP$  the light intensity in units of einsteins per second. Equation 1 is only valid when  $k_3t_fC > 10^3$ , where  $C$  is the bulk concentration of the hydrocarbon. Under these conditions, reaction 3 of Table I is diffusion controlled. Equation 1 requires that a plot of  $\log \omega$  vs.  $(t_r/t_f)^{1/2}$  give a straight line of  $-1.45$ . Equation 1 has been

confirmed for rubrene in several solvents and it has been demonstrated that  $k_3 > 10^6 M^{-1} \text{sec}^{-1}$ .

It is of interest to know the quantum efficiency of electrochemically generated chemiluminescence, and several preliminary estimates have been reported. The most reliable estimates are probably those of Watne,<sup>9</sup> who used a coulometric approach measuring the einsteins emitted per coulomb of electricity consumed. He observed that the quantum efficiency of rubrene in benzonitrile varied depending upon the direction of generation. When the rubrene radical anion was generated first a value of 0.006 was obtained, but when the radical cation was generated first the efficiency increased to 0.015.

Investigators have used radical-ion reactions in an attempt to produce excimers under conditions where they could not be formed by photoexcitation.<sup>10</sup> Therefore excimer reactions have been included in Table I, reactions 8 and 9. Parker and Short<sup>11</sup> have also reported excimer formation by electrochemically generated chemiluminescence under conditions where excimers could normally be formed by the radiative process and observed an enhancement of excimer emission under these circumstances. Workers have shown<sup>12,13</sup> that light emission in some systems attributed to excimer formation can be explained by impurities produced by decomposition of the radical ions. Presently, there is no evidence to indicate that excimer formation is a significant process in electrochemically generated chemiluminescence, and there appears to be mounting evidence to the contrary.

Although the singlet states of hydrocarbons have been identified as emitters in a number of chemiluminescent reactions, there is no reason *a priori* why singlet states should be produced rather than triplet states. Several authors have considered that chemiluminescence could be produced in a situation where insufficient energy is available to form an excited singlet state directly, if triplet states were produced first and triplet-triplet annihilation occurred. This process is indicated by reactions 5 and 6 of Table I. Triplet-triplet annihilation is a well-known phenomenon that is diffusion controlled and consequently could be of importance in chemiluminescent reactions.

In deciding whether or not triplet-triplet annihilation is important in chemiluminescence, one must consider the energetics of radical-ion reactions. Energy calculations are usually based on electrochemical data, and the magnitude of the  $T\Delta S$  correction applied to the electrochemical data becomes important. For most

(9) B. M. Watne, Sc.B. Thesis, Massachusetts Institute of Technology, June 1967.

(10) E. A. Chandross, J. W. Longworth, and R. E. Visco, *J. Amer. Chem. Soc.*, **87**, 3259 (1965).

(11) C. A. Parker and G. D. Short, *Trans. Faraday Soc.*, **63**, 2618 (1967).

(12) J. Chang, T. C. Werner, and D. M. Hercules, Abstracts, 155th National Meeting of the American Chemical Society, San Francisco, Calif., 1968, No. R42.

(13) A. J. Bard, K. S. V. Santhanam, S. A. Cruser, and L. R. Faulkner in "Fluorescence: Theory Instrumentation and Practice," G. G. Guilbault, Ed., Marcel Dekker, New York, N. Y., 1967, Chapter 14.

Table II  
Energetics of Electron-Transfer Reactions<sup>a</sup>

	$E_{1/2}(A \rightarrow A^+)$	$E_{1/2}(A \rightarrow A^-)$	$\Delta E_{1/2}(A^+ + A^-)$	$\Delta E_{1/2}(A^+ + D)$	$\Delta E_{1/2}(A^- + A)$	$E_{\text{singlet, eV}}$
Rubrene	+0.88	-1.47	2.35	1.60	1.63	2.39
9,10-Diphenylanthracene	+1.32	-1.72	3.04	2.04		2.85
9,10-Dimethylanthracene	+1.16	-1.82	3.02	1.88		3.05
Tetracene	+0.83	-1.55	2.48	1.64	1.71	2.58
Naphthoquinone <sup>b</sup>		-0.72				
N,N,N',N'-Tetramethyl- <i>p</i> -phenylenediamine <sup>c</sup>	+0.16					

<sup>a</sup> Unless stated elsewhere, all values are given in volts. <sup>b</sup> *p*-Benzoquinone (-0.60 V) and anthraquinone (-0.80 V) are also used as donors. <sup>c</sup> *p*-Phenylenediamine (+0.24 V) is also used as acceptor.

aromatic systems,  $T\Delta S$  has been estimated to be about 0.2 eV by several workers and has recently been confirmed by measurement.<sup>14</sup> If electrochemical data indicate a large difference between the energy available from a reaction and that necessary for excited singlet formation, the needed energy will have to be supplied by  $kT$  or by a mechanism such as triplet-triplet annihilation.

Several workers have reported that chemiluminescence occurs in systems where insufficient energy is available for direct formation of an excited singlet state. One example is the reaction of the rubrene radical cation with dimethylformamide, amines, and water.<sup>7</sup> Similar results were observed for perylene and 9,10-diphenylanthracene where the energy deficiency was even greater than for rubrene. Although part of the energy discrepancy could be accounted for by irreversible electrode reactions, it seems likely that chemiluminescence was produced by reactions between solvent oxidation intermediates and the radical cation followed by triplet-triplet annihilation.<sup>7</sup>

Weller and Zachariasse<sup>15</sup> have observed chemiluminescence from the reactions of radical anions and Wurster's blue perchlorate in dimethoxyethane. In this situation, it is clear that insufficient energy is available for excited singlet-state formation, based on electrochemical data. Of special interest is the reaction between Wurster's blue cation and the chrysene anion. The energy required for formation of a chrysene singlet is 3.43 eV, but the cation-anion reaction can provide only 2.66 mV. The energy of the chrysene triplet is 2.44 eV, indicating sufficient energy would be available for its formation. Emission spectra showed chemiluminescence matching the fluorescence spectrum of chrysene to within  $\pm 0.1$  nm on each of four vibronic bands. In addition, bands at longer wavelengths were observed with peaks at 1.98, 1.87, and 1.74  $\mu^{-1}$ . These closely correlated with the vibronic peaks observed in the phosphorescence of chrysene at 1.99, 1.86, and 1.71  $\mu^{-1}$ . The close correlation between the structured peaks indicates with fair probability these authors were observing emission from a triplet state of chrysene in fluid solution.

Chang, *et al.*,<sup>16</sup> have shown that radical-ion chemiluminescence of rubrene can be produced when insufficient energy is available to form an excited singlet state. Reaction of the rubrene radical anion with radical cations or the reaction of the rubrene radical cation with radical anions show large discrepancies, as indicated in Table II. For example, rubrene oxidation occurs at +0.88 V *vs.* sce while naphthoquinone reduction occurs at -0.72 V. This gives a net energy of only 1.60 V available from the reaction, although the rubrene excited singlet state requires 2.39 V. Nevertheless, rubrene fluorescence is observed from the reaction of the naphthoquinone anion with the rubrene radical cation.

A combination of other studies has also indicated evidence for triplet production in chemiluminescence.<sup>16,17</sup> Feldberg<sup>17</sup> has extended his treatment of the boundary value problem to the case where triplet-triplet annihilation occurs. Although under normal conditions it is not possible to distinguish between direct singlet formation and production by triplet-triplet annihilation, if a triplet quencher is present the latter reaction can be detected. When significant triplet quenching occurs, the normalized light emission,  $\omega_b$ , is

$$\log \omega_b = -2.90(t_r/t_t)^{1/2} - \log \beta + 1.42 \quad (3)$$

where  $t_r$  and  $t_t$  are as defined in eq 1. The terms  $\omega_b$  and  $\beta$  are complex and for definition the reader is referred to the original paper.<sup>16</sup> Equation 3 indicates that a plot of  $\log \omega$  *vs.*  $(t_r/t_t)^{1/2}$  will yield a slope of 2.90 for triplet quenching. When triplet quenching is absent, eq 3 can be reduced to eq 1. Therefore, slopes ranging between -1.45 and -2.90 in the presence of a triplet quencher would be indicative of the production of triplets in radical-ion reactions.

Chang, *et al.*,<sup>16</sup> have observed that plots of  $\log \omega$  *vs.*  $(t_r/t_t)^{1/2}$  for rubrene over a wide range of  $t_t$  values show slopes varying from -1.45 and -2.90 as predicted by eq 3 for the case of triplet-triplet annihilation in the presence of a triplet quencher. Their results are shown in Figure 5. Although no triplet quencher was intentionally added to their solutions, Chang, *et al.*,<sup>16</sup>

(14) E. A. Chandross and R. E. Visco, paper presented at meeting of the Electrochemical Society, Boston, Mass., 1968.

(15) A. Weller and K. Zachariasse, *J. Chem. Phys.*, **46**, 4984 (1967).

(16) J. Chang, D. M. Hercules, and D. K. Roe, *Electrochim. Acta*, **13**, 1197 (1968).

(17) S. W. Feldberg, *J. Phys. Chem.*, **70**, 3928 (1966).

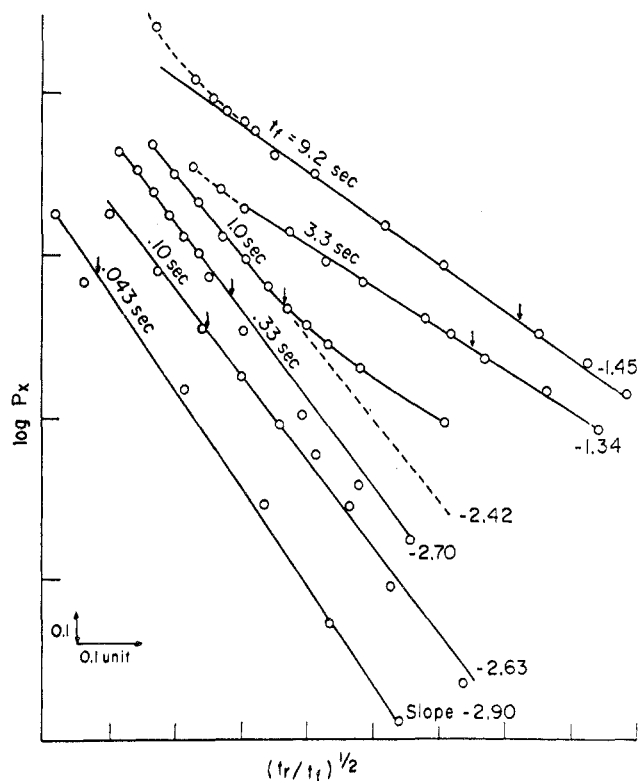

Figure 5. Plots of  $\log P_x$  vs.  $(t_r/t_f)^{1/2}$  for values of  $t_f$  as indicated. Plots have been displaced along the abscissa to avoid overlap. Plots are displaced along the ordinate because of gain of recorder amplifier. Small vertical arrows are located at  $(t_r/t_f)^{1/2} = 0.75$ .<sup>23</sup>

attributed these results to quenching of the rubrene triplet by the cation and anion radicals present in solution. Quenching would depend on the relative probability of a rubrene triplet encountering a radical ion as opposed to another triplet after it was formed in the diffusion layer. When  $t_f$  is small, the volume element of solution in which the radical-ion reaction occurs is small, and the probability that the triplet will migrate out of the reaction region before encountering another triplet is relatively large. If this occurs, the triplet will encounter a radical ion and will be quenched. When  $t_f$  is large the reaction zone is thicker, and it becomes more probable for a triplet to encounter another triplet than to diffuse out of the reaction zone. Although these observations provide indirect evidence for the occurrence of triplet-triplet annihilation, it was not possible to determine from the measurements the percentage of encounters producing a triplet vs. those producing a singlet directly.

**Ruthenium Chelates.** Chemiluminescence can be produced by electron-transfer reactions involving species other than the cations or anions of aromatic hydrocarbons. A brightly chemiluminescing reaction is the reduction of Ru(III) chelates which can be written as<sup>18</sup>



where ruthenium is the metal ion,  $n = 2$ , and 2,2'-bipyridine, 5-methyl-*o*-phenanthroline, 5,6-dimethyl-*o*-phenanthroline, and 3,5,6,8-tetramethyl-*o*-phenanthroline were ligands. Aqueous base or hydrazine served as the reductant. Chemiluminescence spectra were identical with fluorescence spectra of the Ru(II) chelates studied independently.<sup>18</sup> The mechanism of the reaction between ruthenium(III) bipyridine chelates and hydrazine has been studied.<sup>19</sup> Using thermochemical and electrochemical data about 1.4 to 1.5 eV is available from the over-all reaction. On the basis of the fluorescence spectrum of Ru(III) 2.1 eV is necessary for excitation. This leaves a discrepancy of about 0.5 to 0.7 eV in excitation energy. It is not necessary to invoke an energy-doubling mechanism because the ruthenium(III) bipyridine-hydrazine reaction is complex and chemiluminescence could result from reactions involving intermediate species.

The kinetics of the chemiluminescent reaction between the Ru(III) and hydrazine have been studied in some detail.<sup>19</sup> A mechanism to account for the observed kinetics adequately at low concentration has been postulated and is based on the mechanism for the iron(III)-hydrazine reaction, a system which has been extensively studied<sup>20-24</sup> (eq 5-9), where ligands are

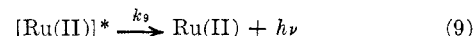
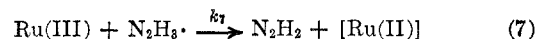
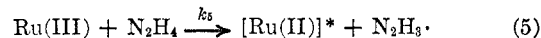

omitted in the formulas. Production of ground-state ruthenium complexes has been omitted in reactions 5 and 8 above but undoubtedly occurs. The kinetic data indicate that reaction 7 does not produce excited states directly, reaction 5 is about 1% efficient, and reaction 8 about 99% efficient. A computer-simulation technique matched chemiluminescence-time curves obtained on a stopped-flow spectrophotometer with the kinetic scheme indicated above and an exact match for low hydrazine concentrations was observed. At higher hydrazine concentrations a qualitative fit was observed, but it was not quantitative. This indicates there is probably an unknown reaction occurring at higher hydrazine concentrations.

The Ru(III)-hydrazine system is readily amenable to mechanistic studies. The nature of the emitter is known as are details about the emission process.<sup>25</sup>

(19) F. E. Lytle, Ph.D. Thesis, Massachusetts Institute of Technology, 1968.

(20) W. C. E. Higginson, D. Sutton, and P. Wright, *J. Chem. Soc.*, 1380 (1953).

(21) W. C. E. Higginson and D. Sutton, *ibid.*, 1402 (1953).

(22) W. C. E. Higginson and P. Wright, *ibid.*, 1551 (1953).

(23) D. R. Rossemsky, *ibid.*, 4685 (1957).

(24) S. W. Cahn and R. E. Powell, *J. Amer. Chem. Soc.*, **76**, 2568 (1954).

(25) F. E. Lytle and D. M. Hercules, *ibid.*, **91**, 253 (1969).

(18) D. M. Hercules and F. E. Lytle, *J. Amer. Chem. Soc.*, **88**, 4745 (1966).

The reaction pathway is known in terms of the chemical steps which occur in dilute solution and those steps which produce excited states. It is of particular interest that at least two reactions in the systems produce excited states. Although simple thermodynamic considerations indicate the production of an excited state in this reaction is not possible, because of the complex reaction mechanism such calculations are of questionable validity. This points out the necessity

for using thermodynamic calculations only in those situations where both the oxidant and the reductant undergo simple one-electron-transfer reactions.

*I wish to thank Professor David Roe, Jack Chang, Robert Lansbury, Fred Lytle, and Bruce Watne, all of whom made major experimental contributions to the work discussed in this article. This work was supported in part through funds provided by the U. S. Atomic Energy Commission under Contract AT(30-1)-905.*

## Applications of Isotropic Shifts to the Investigation of Structures and Structural Equilibria of Metal Complexes

RICHARD H. HOLM

Department of Chemistry, Massachusetts Institute of Technology, Cambridge, Massachusetts 02139

Received February 3, 1969

During the development of nuclear magnetic resonance as a spectroscopic tool for structure determination, attempts to observe the nmr spectra of paramagnetic species in solution under high-resolution conditions were occasionally unsuccessful, or at best gave broad featureless signals whose line widths rather than chemical shifts were the important characteristics. Such observations were no doubt responsible for numerous cases in the literature in which the nmr spectra of metal complexes were not recorded for the reason, stated or implied, that the complexes were paramagnetic. Although the proton resonance spectra of several paramagnetic complexes in solution had been reported<sup>1</sup> and the sources of the observed paramagnetic or isotropic shifts were fully realized earlier,<sup>2</sup> the potential utility of the spectra of such species did not become evident until 1960–1962, when Eaton, Phillips, and co-workers presented a detailed analysis of the <sup>1</sup>H and <sup>19</sup>F spectra of a wide variety of substituted nickel(II) aminotroponiminates.<sup>3</sup>

The spectra of these complexes, which are fully tetrahedral or are involved in rapid planar ⇌ tetrahedral structural equilibria in noncoordinating solvents, revealed the isotropic shift phenomenon in the form of

large displacements of resonance frequencies upfield and downfield from their nominal diamagnetic positions, with retention of narrow line widths. For proton signals at ambient temperature these displacements, *i.e.*, isotropic shifts, cover in some cases a 310-ppm range, from -170 (downfield) to +140 ppm (upfield). Perspicacious interpretation of these spectra has provided a new and exceedingly sensitive technique for detecting delocalization of unpaired electrons, investigating pathways of spin delocalization, and obtaining accurate values of the thermodynamic parameters characterizing the structural equilibria. The aminotroponiminates provided the first practical examples of the utility of nmr spectra of paramagnetic complexes in solution, and the use of isotropic shifts in the investigation of structural and electronic properties of complexes of nickel(II) and other metal ions with favorably short electronic relaxation times has become more widespread since the first major publication<sup>20</sup> of the Du Pont group.

The total isotropic shift of the *i*th nucleus in a paramagnetic species is defined as

$$(\Delta H_i/H_0)_{\text{total}} = (\Delta H_i/H_0)_{\text{obsd}} - (\Delta H_i/H_0)_{\text{dia}} \quad (1)$$

in which  $(\Delta H_i/H_0)_{\text{obsd}}$  is the observed shift and  $(\Delta H_i/H_0)_{\text{dia}}$  the shift in the absence of the paramagnetic effect. Both are measured with respect to the same internal standard to avoid bulk susceptibility corrections. For paramagnetic metal complexes values of the latter shift are generally taken from the spectra of free ligands or structurally related, diamagnetic complexes such as those of zinc(II) and cobalt(III). The total isotropic shift (eq 2) is a sum of contributions from the scalar (or Fermi) isotropic hyperfine contact interaction, which arises from electron spin delocalization or spin polarization, and the nuclear-electron dipolar interaction. Derivations of equations appropriate to these

(1) H. M. McConnell and C. H. Holm, *J. Chem. Phys.*, **27**, 314 (1957); **28**, 749 (1958); W. D. Phillips, C. E. Looney, and C. K. Ikeda, *ibid.*, **27**, 1435 (1957); A. Forman, J. N. Murrell, and L. E. Orgel, *ibid.*, **31**, 1129 (1959).

(2) For a discussion of isotropic shifts and a review of the nmr spectra of paramagnetic species, *cf.* D. R. Eaton and W. D. Phillips, *Advan. Magnetic Resonance*, **1**, 103 (1965); E. de Boer and H. van Willigen, *Progr. Nucl. Magn. Resonance Spectrosc.*, **2**, 111 (1967).

(3) (a) W. D. Phillips and R. E. Benson, *J. Chem. Phys.*, **33**, 607 (1960); (b) R. E. Benson, D. R. Eaton, A. D. Josey, and W. D. Phillips, *J. Am. Chem. Soc.*, **83**, 3714 (1961); (c) D. R. Eaton, A. D. Josey, W. D. Phillips, and R. E. Benson, *J. Chem. Phys.*, **37**, 347 (1962); (d) D. R. Eaton, A. D. Josey, W. D. Phillips, and R. E. Benson, *Discussions Faraday Soc.*, **34**, 77 (1962); (e) D. R. Eaton, A. D. Josey, W. D. Phillips, and R. E. Benson, *Mol. Phys.*, **5**, 407 (1962); (f) D. R. Eaton, A. D. Josey, R. E. Benson, W. D. Phillips, and T. L. Cairns, *J. Am. Chem. Soc.*, **84**, 4100 (1962).